

ORBIWELD 170

Enclosed orbital weld head

The ORBIWELD 170 is characterized by very high thermal resistance. It is therefore particularly suitable for applications in the chemical, pharmaceutical, food and beverage industry, where ever greater demands are made on the closed weld heads by ever greater tube diameters and wall thicknesses.



Coolant channels running through the entire weld head body ensure an excellent heat dissipation that enable the ORBIWELD weld head to work continuously even at high welding currents and intensive loady.

The closed design of the ORBIWELD 170 and the gas management system of the head ensure a permanent infiltration of the weld seam during welding with inert gas, guaranteeing seams that are very low in welding colors.

FEATURES:

- Quick change system for clamping inserts that engages and releases smoothly without any tools
- High durability due to completely liquid-cooled weld head housing
- Durable clamping connections in combination with clamping inserts available for all tube dimensions guarantee that the parts to be welded are clamped securely without misalignment

- All the important commands for welding can be transmitted to the power supply via a control panel built into the robust and durable aluminum handle, so that no additional remote control is required
- High-quality, rugged housing and handle parts
- Highly flexible hose package (Length: 7.5 m/ 24.6 ft) with strain relief to the power supply
- Cost-effective clamping inserts
- Comprehensive and customer-specific range of accessories

Comprehensive and customer-specific range of accessories (available option):



Hose package length extensions up to max. of 20 m (64 ft)



Cost-effective clamping inserts

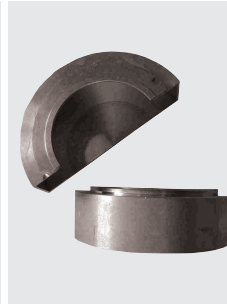

Cavity inserts for moldings for welding of shaped pieces

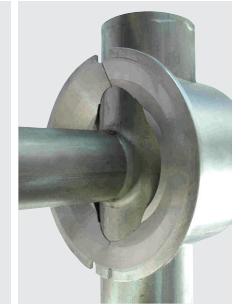

T-piece clamping inserts with the ability to clamp the hollowed tube and the tube to be welded

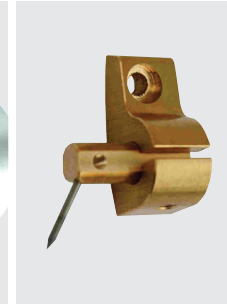

Electrode adapters for transverse alignment of the tungsten electrode



Practical and sturdy (anodized) aluminum table mounts

APPLICATION RANGE	ORBIWELD 170
Code	825 000 001
Tube OD, min. - max.	50 - 170 mm 2" - 6"
Electrode Ø	1.6/2.4 mm 0.063"/0.094"
Machine weight including hose package	18.9 kg 41.7 lbs
Hose package length	7.5 m 24.6 ft
SCOPE OF DELIVERY	
Including:	<ul style="list-style-type: none"> • 1 Enclosed orbital weld head OW 170 • 1 Durable storage and shipping case (Code 821 030 001) • 1 Tool set • 1 Power connector adapter • 1 Feeler gauge • 1 Operating instructions and spare parts list
Suitable accessories (available option):	<ul style="list-style-type: none"> • Clamping inserts, small and wide • Cavity inserts for moldings • Inserts for elbow welding • T-piece clamping inserts • Electrode adapters • Table mounts • ESG tungsten grinders • ORBmax residual oxygen meter • ORBIPURGE forming set • Hose package extensions • Pressure regulator • WS2 tungsten electrodes

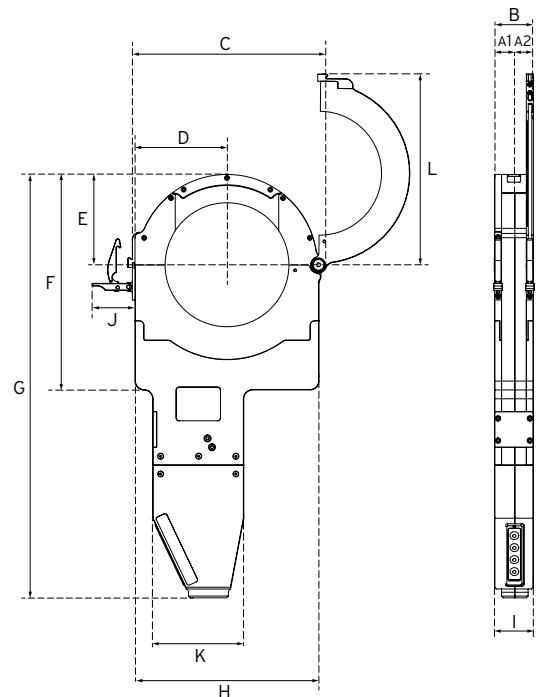

ORBIWELD 170	DIMENSION		ELECTRODE INTERVAL			
			CLAMPING INSERT TYPE "S" [2 PAIRS]		CLAMPING INSERT TYPE "W" [2 PAIRS]	
	[MM]	[INCH]	[MM]	[INCH]	[MM]	[INCH]
Dimension "A1"	30.00	1.181	32.00	1.260	50.00	1.969
Dimension "A2"	41.00	1.614	43.00	1.693	61.00	2.402
Dimension "B"	70.00	2.756	72.00	2.835	110.00	4.331
Dimension "C"	345.00	13.583				
Dimension "D"	160.00	6.299				
Dimension "E"	140.00	5.512				
Dimension "F"	365.00	14.370				
Dimension "G"	585.00	23.031				
Dimension "H"	285.00	11.220				
Dimension "I"	50.00	1.969				
Dimension "J"	67.00	2.638				
Dimension "K"	88.00	3.465				
Dimension "L"	332.00	13.071				



ORBIWELD 170

The technical data are not binding. They are not warranted characteristics and are subject to change.